

# Digital torque wrench CEM10N3X8D-G-BT

Type CEM3-G-BT, LCD display, direct reading, 2-10Nm

Item number: CEM10N3X8D-G-BT

Packing unit: 1



Digital torque spanner with integrated Bluetooth® data transmission for precise screwdriving and inspection applications.

- Measurement of torque and angle (can be activated separately)
- Wireless data transmission via Bluetooth®
- Two operating modes: simplex and duplex
- Simple operation via maintenance keypad
- Compatible with interchangeable heads from Tohnichi
- Free TDMS app (iOS & Android) for data acquisition and management

**Simplex mode:**

Transmits measurement data directly to the PC or stores it for later transmission.

**Duplex mode:**

Receives specifications (e.g. torque, number of pieces) from the PC and sends back results after each tightening.

## TECHNICAL CHARACTERISTICS

Drive (,,):	¼
Version:	Ratchet head
Torque (Nm):	2 - 10
Direction:	Right / Left
Accuracy (%):	+/-1
Type of head:	8D
Graduation (Nm):	0.01
Manufacturer:	Tohnichi Manufacturing Co., Ltd.

## DIMENSIONS

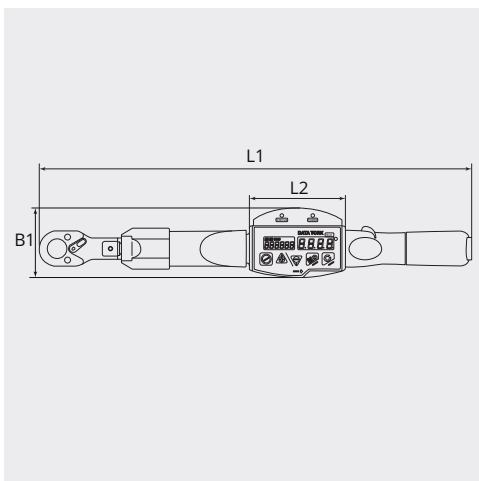

## DIMENSIONS

L1 (mm):	212
L2 (mm):	100
B1 (mm):	72